

Exhibitor Prospectus

5-6-7 February 2025

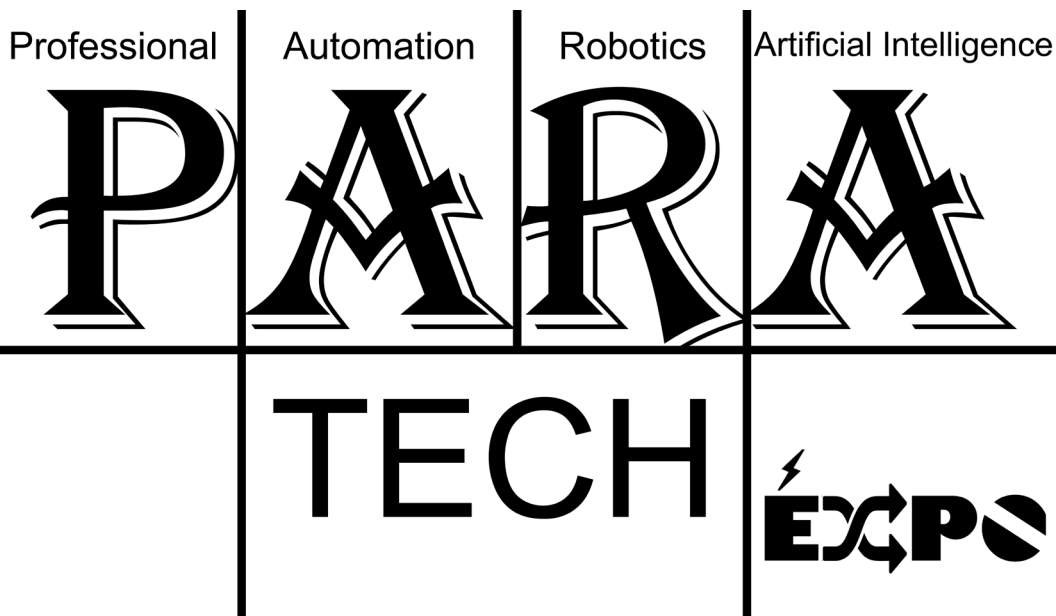

Sourcing Solutions in Industrial Automation

**Venue: CIDCO Exhibition & Convention Centre
(CECC), Vashi, Navi Mumbai-400703**



imprintTM
Automation India
Magazine

InfocastTM
Information Casting
| Magazine | Expo | Conference |

**6C/5, Sangeeta Apts, Juhu Tara Road, HS Revdankar
Marg, Santacruz(W), Mumbai - 400049**

Robots & Cobots

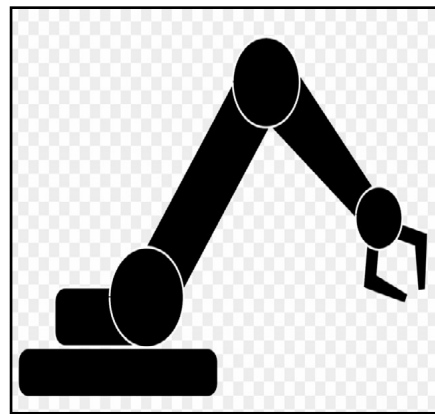

Articulated

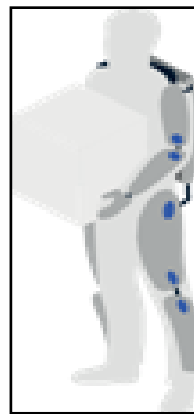

Exoskeletons



Articulated

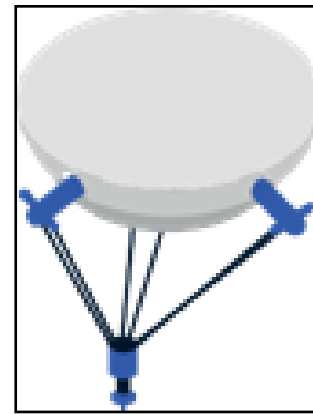

Delta

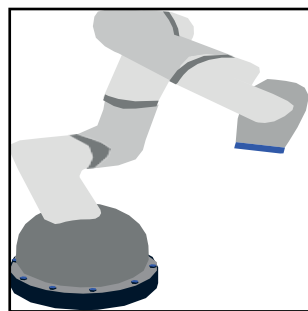

Collaborative

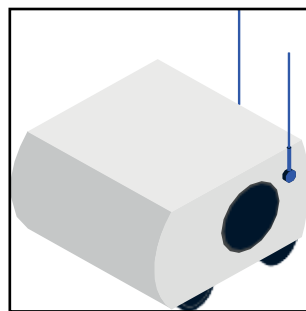

AGVs & AMRs

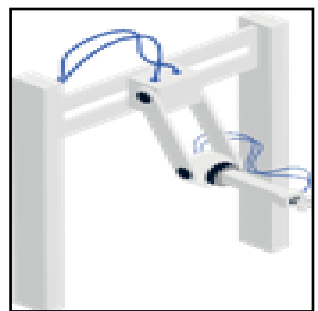

Gantry/linear/Cartesian

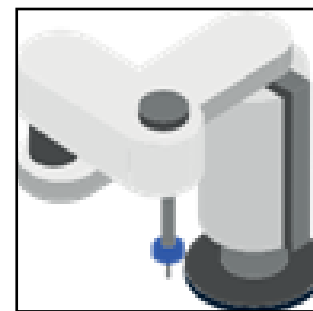

SCARA



Mobile robots

Automation Growth Story

Automation growth in Manufacturing, packaging, warehousing is 17-20%. 5G connectivity, IIOT is spurring adoption of automation. Information on cost-effective solutions as well as future-proof solution is imperative.

Imprint Automation India magazine is a valid response to an urgent need of Indian manufacturing industry to source and connect with the right company for the correct solution.

The India Industrial Automation Market size is expected to grow from USD 13.23 billion in 2023 to USD 25.76 billion by 2028, at a CAGR of 14.26% during the forecast period (2023-2028).

The India Warehouse Automation Market size is expected to grow from USD 267.07 million in 2023 to USD 880.98 million by 2028, at a CAGR of 26.96% during the forecast period (2023-2028).

The packaging automation market is currently valued at US\$ 74.53 Bn in 2023. By 2033, demand for Packaging Automation is expected to reach a high of US\$ 161.66 Bn, the report adds.

The Pharmaceutical Automation Market is projected to reach \$18.2 billion by 2029 at a CAGR of 12% from 2022 to 2029. The growth of this market is attributed to the increasing adoption of robots in pharmaceutical manufacturing, government initiatives to promote industrial development, rising investments in transforming conventional production facilities, and growing demand for safe and digitized production processes.

The growing demand for IoT in pharmaceutical manufacturing is expected to offer significant opportunities for the growth of this market

Highlights at PARA Tech Expo 2025

1. Exclusive Exhibitors only engagement with global pundits of automation. This session will give guidance on impact of latest technology in automation. Where lies the future return on investment. The impact of 5G on remote automation. Artificial intelligence and its impact on machine, IIOT (4.0) and digital transformation.

2. CEO Conclave white paper on March of Automation in manufacturing in India—strategy for government and private industry.

Features:

1. Pharmaceutical Automation.
2. Packaging Automation.
3. Warehouse Automation.

3. **Pharma Conclave:** Meet Pharma Association to discuss automation initiatives in pharma industry make connection get business.

4. **Packaging Conclave:** Meet Packaging Association to discuss automation initiatives in Packaging industry make connection get business.

5. **Warehouse Conclave:** Meet Warehouse Association to discuss automation initiatives in Warehouse industry make connection get business.

MAHARASHTRA INDUSTRIAL DEVELOPMENT CORPORATION
(A Government of Maharashtra Undertaking)



Date: 04/04/2024

To
Shri Anil Chopra
PARA Tech Expo
Infocast Systems Pvt Ltd
6C/5 Sangeeta Apartments,
Revdandkar Marg, off Juhu Tara Road, Mumbai 400049

The State of Maharashtra has established itself as the Industrial Powerhouse of India and has been able to develop integrated ecosystems in Automobile and Engineering manufacturing.

We welcome the initiative of Infocast Systems in organising PARA Tech Expo 2025 at CECC, Vashi, NAVI Mumbai, Maharashtra, which will help contribute to Maharashtra's economy by attracting investment in automation sector to build the momentum to establish Maharashtra as the core automation technology destination in India.

Furthermore, such initiatives will also help build the required skill pool of automation engineering professionals in Maharashtra, thereby developing the ecosystem for automation industry to flourish.

We appreciate this initiative by Infocast and wish them all the best for this endeavour.

Warm Regards,

Dr. Vikas Suryawanshi
General Manager (Marketing)
MIDC HQ, Mumbai

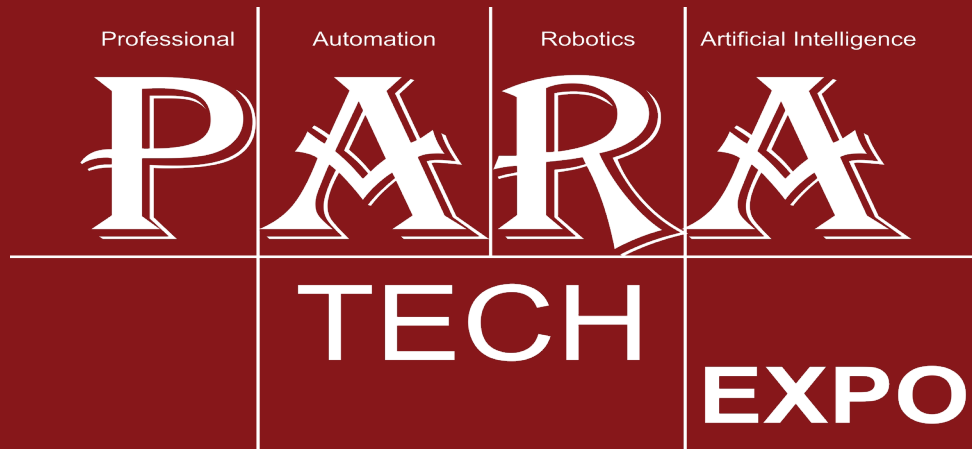
Pro Automation, Robotics & Artificial Intelligence Exhibition



Sourcing solutions in industrial Automation

HALL 1

- Industrial Automation
- Industrial Robotics
- Machine Learning
- Sensors
- Cobots
- PLCs
- AGV

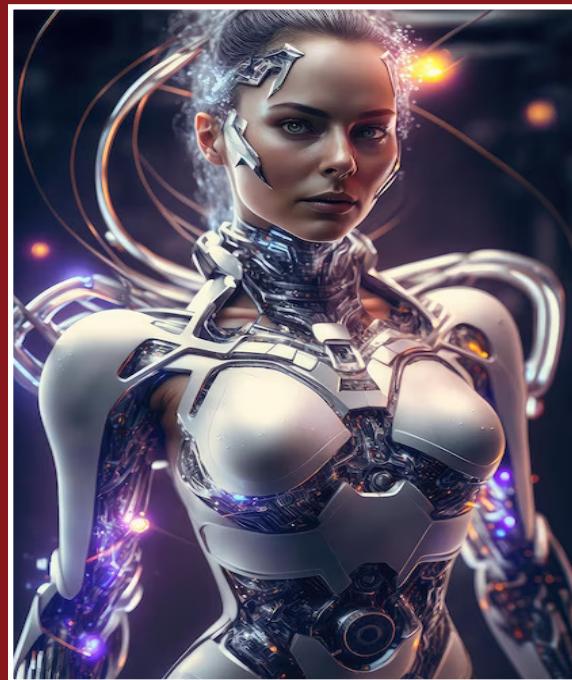

HALL 2

- Digital Transformation
- Artificial Intelligence
- Edge Computing
- Cyber Security
- Digital Twins
- VR & AR
- IIOT

5-6-7 FEBRUARY 2025

BOOK YOUR BOOTH NOW

Early Bird Discount ends 30 June 2024

Organized By

Infocast™
Information Casting
Expo | Magazine | Seminar

www.infocast.in

Managed By

imprint™
Automation India
Magazine

www.imprint-magazine.in

Industrial Automation Leads to Excellence

imprint Automation Grid

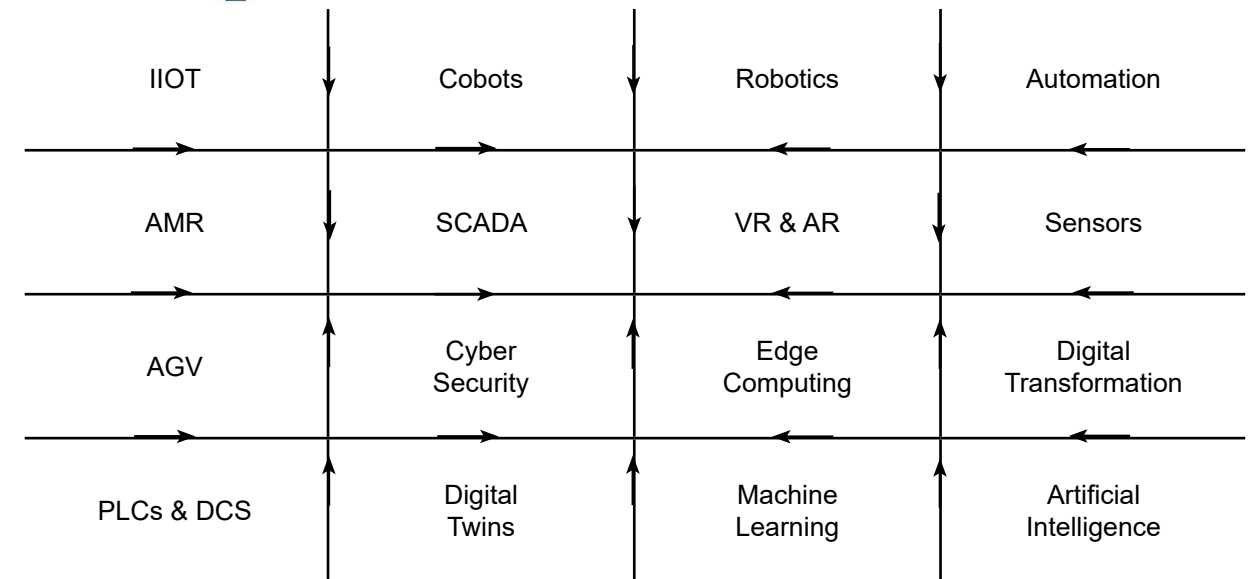

Copyright Grid. Do not use without permission

March of automation in manufacturing

VENUE: CIDCO Exhibition & Convention Centre (CECC), VASHI, NAVI MUMBAI 400703

CONFERENCE

3 Day conference with leading speakers on important topics
CEO Round Table Conclave

BOOK YOUR SPACE

Anchal Tiwari
9821135542
anchal.tiwari@imprint-magazine.in

VISIT THE SHOW

Deepali Jaiswar
9821135542
imprintmagazine84@gmail.com

Benefits of Attending PARA Tech Expo

- **Information:** Latest innovation to assist your solution.
- **Strategy:** Discover strategy to integrate automation in your manufacturing. PARA Tech Expo first mantra >> Industrial automation leads to excellence <<
- **Talent:** Meet professionals with expertise join your company. Imprint alert 1 >> Grave storage of engineers and lack of talent <<
- **Future security:** Adopt future proof automation solutions secure ROI on investment in automation.
- **Analyse:** Understand your product automated manufacturing vis-a-vis competitive solution and process select the most appropriate automation.
- **Knowledge:** Benefit from your presence to attend meaningful conference sessions and seminars.
- **Opportunity:** Professionals and companies attend Industries specific association concourse for your product and automation solutions or service.



Shell Scheme

Area	Table	Chairs	Spotlights	Plug points	Dustbin
9 sq.m	Free As required				
12 sq.m	Free As required				
15 sq.m	Free As required				
18 sq.m	Free As required				
21 sq.m	Free As required				
24 sq.m	Free As required				
28 sq.m	Free As required				

Limited booths for Exhibits.

Book your booth

Confirm your company participation.

Before early bird discount of 5% ends on 30 June 2024.

Each 9 sqm includes complementary:

- 2 conference registration
- 2 lunches
- 1 Full Page Ad. in imprint automation india magazine
- Listing in directory
- Website Company Listing with all links and logos
- Website Product Listing
- Half page Corporate Profile in imprint automation india magazine
- Half page Products Profile in imprint automation india magazine



Raw Space
₹ 14,000 per sqm
\$ 170 per sqm

Shell Scheme
₹ 15,000 per sqm
\$ 180 per sqm

Industry Sectors

Factory Automation	Warehouse Automation	Cyber Security
Process Automation	Industrie 4.0	Digital Twins
Field Instrumentation	Machine Vision	VR & AR
Valves & Valve Automation	Industrial Automation	IIoT
Turnkey Solutions	Industrial Robotics	PLCs & DCS
Hydraulics & Pneumatics	Machine Learning	AGV
Cyber Security	Digital Transformation	Sensors
Control Rooms	Artificial Intelligence	Cobots
Electric Automation	Edge Computing	

Overview of PARA Tech Expo & Conference 2025

Estimated

Exhibitors 350 +	Attendees 12000 +	Technology Companies 350 +
Brands 400 +	Solutions Providers 400 +	Buyers Significant % of Attendees

Infocast Systems Pvt Ltd

Communicating critical knowledge to Professionals to deliver business. Infocast - Information Casting to industry to build business equitably.



Infocast Systems Private Limited publishes Imprint Automation India magazine on professional automation, robotics, artificial intelligence. Imprint Automation India Magazine won the media partner award at PPPA 2024 Meet organized by International Society of Automation, Chicago. ISA maharashtra section Imprint is the strength of purpose driving PARA Tech Expo 2025, International Expo on Industrial Automation, Manufacturing Robotics and Machine Learning Artificial Intelligence. Infocast has a rich history of creating exhibitions which contributed to tremendous growth of the industry. Infocast exhibitions and magazines' mantra is to develop the Indian market with latest technology. PARA Tech Expo aims to impact India's automation industry with this mantra-latest technology. Infocast, Imprint Automation India, and PARA Tech Expo believe Industrial Automation leads to excellence, and goal is March of Automation in manufacturing in India.

38 years of motivating the market and putting technology in place.

Infocast Systems Private Limited has a rich history of professionalism in organizing trade exhibitions for the pro audio industry, cinema technology industry, optical media manufacturing industry, broadcast industry, computer graphics animation industry. Infocast has a track record of organizing seminars and awards in Dubai which were instrumental in starting production of optical media in Iran, Egypt, Turkey, Pakistan, other countries which relied upon Optical Disc Systems magazine and Infocast Systems seminars.

Technology first is the mantra of Infocast. Our own motivation lies in our pure understanding technology is the key for growth of industry and professionals. Therefore, our first step is to create a magazine that will update professionals and companies on latest technology and innovation. Infocast has been publishing technology magazine and creating trade expos for 38 years.

Infocast and Imprint Automation India Magazine our younger and determined to do justice to India's automation industry by providing a neutral and independent magazine and trade expo.

Imprint Automation India Magazine

Wow! The Right Catalyst !!

Automation growth in Manufacturing, packaging, warehousing is 17-20%. 5G connectivity, IIOT is spurring adoption of automation. Information on cost-effective solutions as well as future-proof solution is imperative.

Imprint Automation India magazine is a valid response to an urgent need of Indian manufacturing industry to source and connect with the right company for the correct solution.

Mediakit

Contents

Editorial Calender

Automation Trends

Automation Robotics

Automation Product News

Industrial Automation Artificial Intelligence

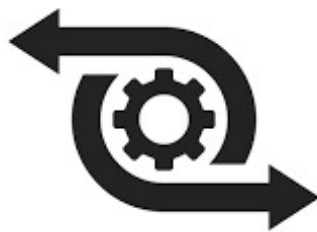

VOL 62 | ISSUE 05 | ENGLISH - BY MONTHLY | JANUARY - FEBRUARY 2024 | PAGE - 48 | PRICE : RS 15 | RNI no.6178/61

imprint™
Automation India
Magazine

India's Automation Magazine

COVER STORY

• Automation News
Articles in this issue:
• Automation Robotics
• Artificial Intelligence
• Automation Trends

Where have all the Engineers Gone ?

Page 29

5-6-7 FEBRUARY 2025
CECC NAVI MUMBAI

ISA Maharashtra Section

PPPA MEET 2-3-FEBRUARY 2024

Full conference topics and speaker details

Page 10

Infocast™
Information Casting
Expo | Magazine | Seminar
www.infocast.in

www.imprint-magazine.in